

FEMALE END VIEW

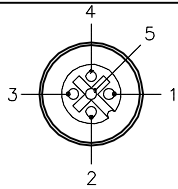

- 1 = BROWN
- 2 = WHITE
- 3 = BLUE
- 4 = BLACK
- 5 = GRAY



SPECIFICATIONS

CONTACT CARRIER MATERIAL	NYLON OR TPU
MOLDED HEAD MATERIAL/COLOR	TPU/YELLOW
CONTACT MATERIAL/PLATING	BRASS/GOLD
COUPLING NUT MATERIAL/PLATING	BRASS/NICKEL
RATED CURRENT [A]	4.0 A
RATED VOLTAGE [V]	250 V
OUTER JACKET MATERIAL/COLOR	TPU/GRAY
CONDUCTOR INSULATION MATERIAL	PVC
NUMBER OF CONDUCTORS [AWG]	5x22 AWG
TEMPERATURE RANGE	-40°C to +90°C (-40°F to +194°F)
PROTECTION CLASS	NEMA 1,3,4,6P AND IEC IP68, IP69K

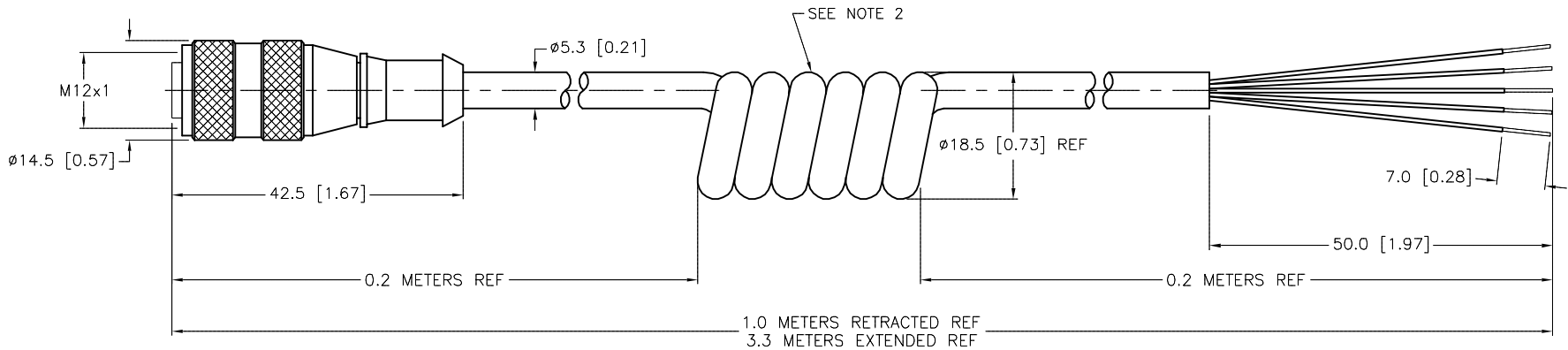

SOURCE DRAWING - FOR REFERENCE ONLY

NOTES:

1. "/S90" DESIGNATES THERMOPLASTIC POLYURETHANE (TPU) CABLE.
2. NUMBER OF COILS IS REFERENCE ONLY.

RELATED DOCUMENTS		3RD ANGLE PROJECTION		THIS DRAWING IS CONFIDENTIAL AND THE PROPERTY OF TURCK INC. USE OF THIS DOCUMENT WITHOUT WRITTEN PERMISSION IS PROHIBITED.		TURCK INC High Technology Sensors and Automation Controls 3000 CAMPUS DRIVE MINNEAPOLIS, MN 55441 1-800-544-7769 (763) 553-7300 (763) 553-0708 fax turck.com	
1. 2. 3. 4.				DRFT RWC DATE 02/21/07 APVD SCALE 1=1.0		DESCRIPTION RK 4.5T-3.3/S90-SP	
MATERIAL SEE SPECIFICATIONS		ALL DIMENSIONS DISPLAYED ON THIS DRAWING ARE FOR REFERENCE ONLY		UNIT OF MEASUREMENT MILLIMETER [INCH]		IDENTIFICATION NO. U0907-18	
FINISH SEE SPECIFICATIONS		CONTACT TURCK FOR MORE INFORMATION		DO NOT SCALE THIS DRAWING		REV H	
H UPDATE CABLE DIAMETER		RDS 11/20/13 43834		FILE: U0907-18		SHEET 1 OF 1	
REV DESCRIPTION		BY DATE ECO NO.					